

CAMBRIDGE INTERNATIONAL EXAMINATIONS
Joint Examination for the School Certificate
and General Certificate of Education Ordinary Level

BIOLOGY

5090/1

PAPER 1 Multiple Choice

OCTOBER/NOVEMBER SESSION 2002

1 hour

Additional materials:

Multiple Choice answer sheet

Soft clean eraser

Soft pencil (type B or HB is recommended)

TIME 1 hour

INSTRUCTIONS TO CANDIDATES

Do not open this booklet until you are told to do so.

Write your name, Centre number and candidate number on the answer sheet in the spaces provided unless this has already been done for you.

There are **forty** questions in this paper. Answer **all** questions. For each question, there are four possible answers, **A**, **B**, **C** and **D**. Choose the **one** you consider correct and record your choice in **soft pencil** on the separate answer sheet.

Read very carefully the instructions on the answer sheet.

INFORMATION FOR CANDIDATES

Each correct answer will score one mark. A mark will not be deducted for a wrong answer.

Any rough working should be done in this booklet.

- 1 Which structures are found in animal cells and in plant cells?
- A cell membrane and chloroplasts
 - B cell membrane and nucleus
 - C cell wall and chloroplasts
 - D cell wall and nucleus
- 2 The photomicrograph shows some human blood cells.



magnification = $\times 900$

What is the function of these cells?

- A transport of amino acids
- B transport of glucose
- C transport of oxygen
- D transport of water

- 3 The diagram shows two plant cells, **X** and **Y**.
Cell **X** has a higher water potential than cell **Y**.

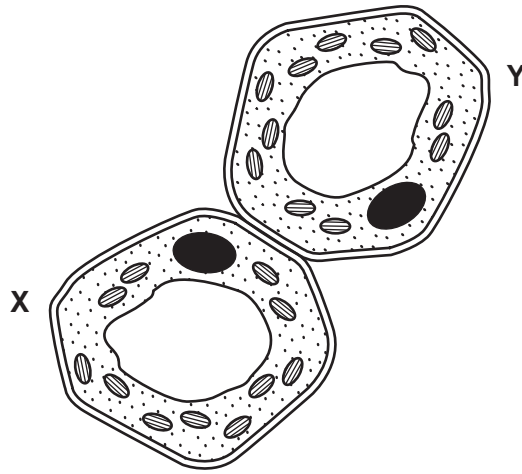

In which direction and by what process will water move between these two cells?

	direction	process
A	X to Y	active transport
B	X to Y	osmosis
C	Y to X	active transport
D	Y to X	osmosis

- 4 Which statement about enzymes is correct?
- A** They are all proteins.
 - B** They are changed by the chemical reactions they control.
 - C** They are destroyed by temperatures below 10 °C.
 - D** They are found only in the alimentary canal.

- 5 Four test-tubes are set up as shown.

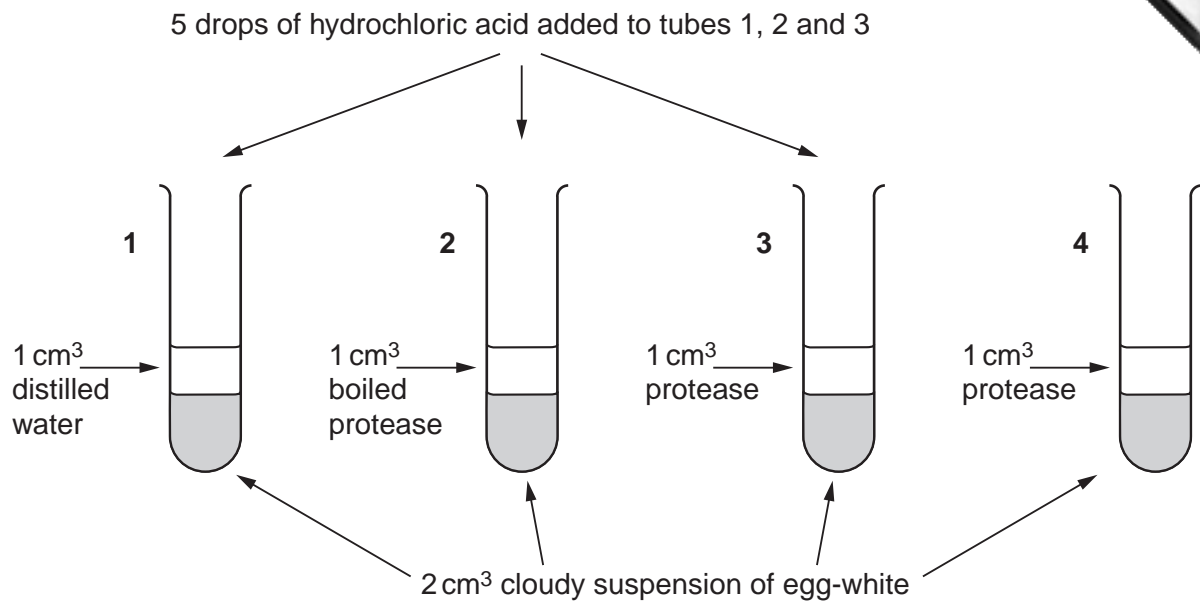

All four tubes are then placed in a water-bath at 37 °C for 20 minutes.

What is the result?

	tube number			
	1	2	3	4
A	clear	clear	clear	clear
B	clear	cloudy	cloudy	clear
C	cloudy	cloudy	clear	cloudy
D	cloudy	clear	cloudy	clear

- 6 The graph shows the rate of photosynthesis in a pea plant in an atmosphere containing 0.04% carbon dioxide at different light intensities.

At which point on the graph is carbon dioxide concentration a limiting factor?

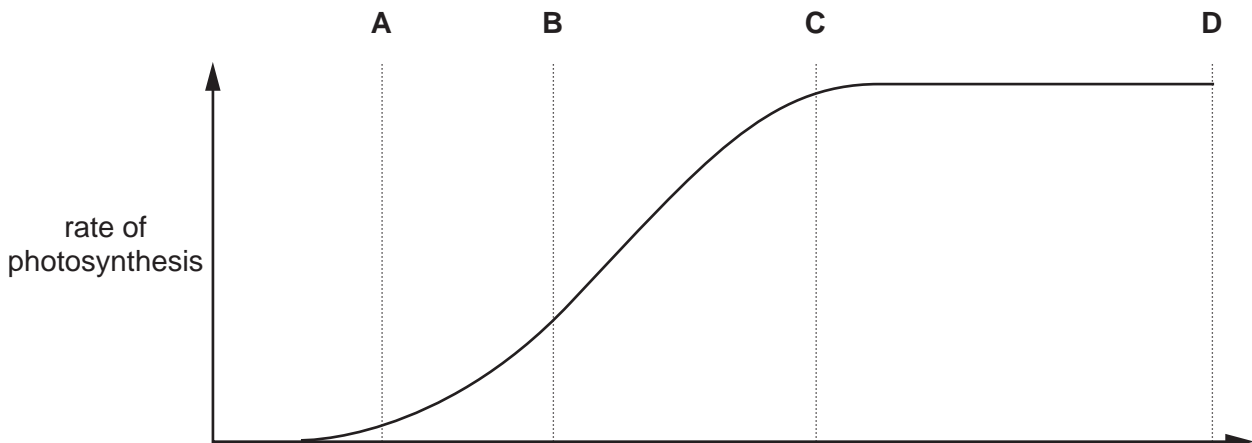

7 For which processes do plants need either nitrate ions or magnesium ions?

	synthesis of cellulose	synthesis of chlorophyll	synthesis of proteins
A	✓	✓	✓
B	✓	✓	✗
C	✓	✗	✗
D	✗	✓	✓

key

✓ needed

✗ not needed

8 A geranium plant has leaves that are green in the centre but white around the edges.

The plant is destarched and then has one of its leaves partly covered with black paper on both sides of the leaf, as shown.

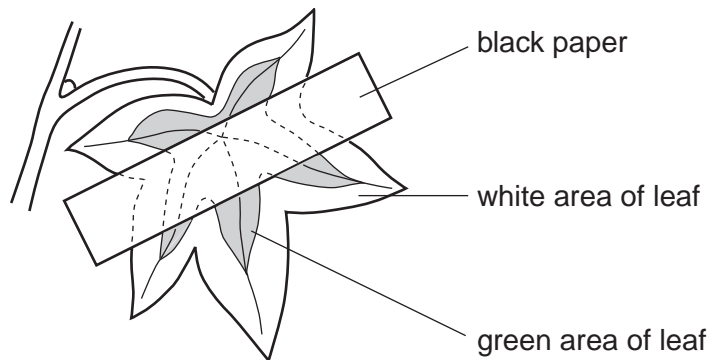

The plant is placed in bright light for 48 hours. The leaf is then tested for starch.

Which diagram correctly shows the areas that contain starch?



A

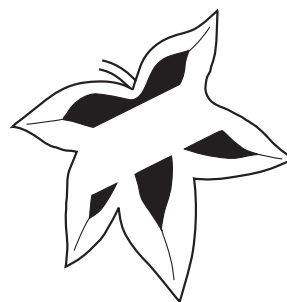

B

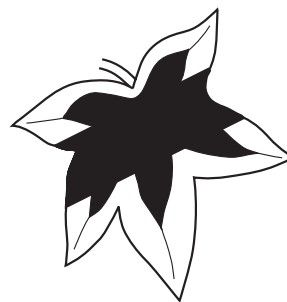
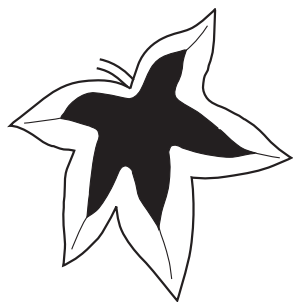

9 Where is lipase produced, and into which part of the intestine is it secreted?

	produced in	secreted into
A	liver	duodenum
B	liver	ileum
C	pancreas	duodenum
D	pancreas	ileum

10 Which dietary imbalance does **not** lead to the health problem stated?

	dietary imbalance	health problem
A	lack of fresh fruit	constipation and scurvy
B	lack of milk and cod liver oil	rickets and diarrhoea
C	too many sweets and cakes	anaemia and rickets
D	too much full-fat cheese and fried food	chronic heart disease

11 What are the functions of the colon?

	water absorbed	enzymes secreted
A	no	no
B	no	yes
C	yes	no
D	yes	yes

- 12 The table shows the results of an investigation into the absorption of products of digestion in the presence and absence of oxygen.

product of digestion	absorption in the presence of oxygen / arbitrary units	absorption in the absence of oxygen / arbitrary units
amino acids	5.3	1.7
fatty acids	1.9	2.0
glucose	6.4	2.3
glycerol	4.8	4.7

Which conclusion can be drawn from these results?

- A All products of digestion are absorbed by both active transport and diffusion.
 B All products of digestion are absorbed by diffusion only.
 C Amino acids and glucose are absorbed by active transport only.
 D Fatty acids and glycerol are absorbed mainly by diffusion.
- 13 The diagram shows cells in part of a green plant.

Which region contains cells that are responsible for the transport of water?

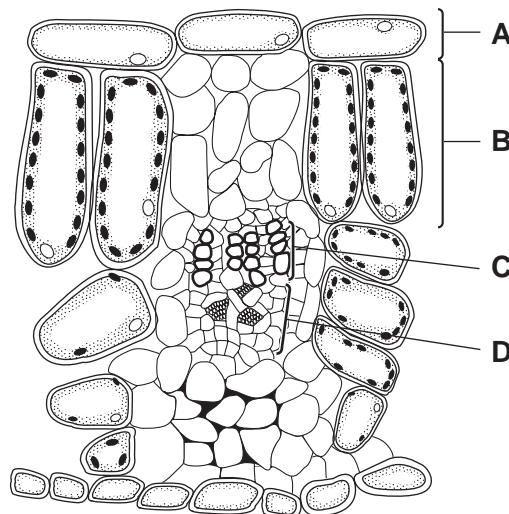

- 14 Which conditions will increase the transpiration rate of a plant?

	temperature	humidity
A	high	high
B	high	low
C	low	high
D	low	low

- 15 The table shows features of some blood vessels.

Which is the pulmonary artery?

	feature			
	muscle layer	lumen	direction of blood flow	blood
A	thick	narrow	away from the heart	deoxygenated
B	thick	wide	away from the heart	oxygenated
C	thin	narrow	towards the heart	oxygenated
D	thin	wide	towards the heart	deoxygenated

- 16 Blood samples from three veins in the body were tested for the concentration of oxygen, carbon dioxide and urea. The results, in arbitrary units, are shown in the table.

vein	oxygen concentration	carbon dioxide concentration	urea concentration
1	40	48	1.5
2	40	48	7.5
3	90	40	4.0

The blood from which veins was sampled?

	hepatic vein	pulmonary vein	renal vein
A	1	2	3
B	2	3	1
C	3	1	2
D	3	2	1

17 What happens during anaerobic respiration in muscles?

	carbon dioxide produced	oxygen used	water produced
A	no	no	no
B	no	yes	yes
C	yes	no	yes
D	yes	yes	no

18 Which process does **not** require energy?

- A** contraction of muscles
- B** synthesis of proteins
- C** tissue respiration
- D** transmission of nerve impulses

19 The table shows the percentage composition of four samples of air.

Which sample could have been breathed out by a person after vigorous exercise?

sample	oxygen	carbon dioxide	water vapour
A	16	0.3	saturated
B	16	4	saturated
C	21	0.03	trace
D	21	3	trace

20 What happens to blood as it passes through a kidney machine?

- A** Carbon dioxide is removed.
- B** Glucose is added.
- C** Oxygen is added.
- D** Urea is removed.

- 21 What happens to the arterioles near the surface of the skin when the body temperature rises?
- A They absorb oxygen from the surrounding tissues.
 - B They dilate and become wider.
 - C They move nearer the skin surface.
 - D They take in water from the surrounding tissues.

- 22 The diagram shows the main muscles and bones of the arm.

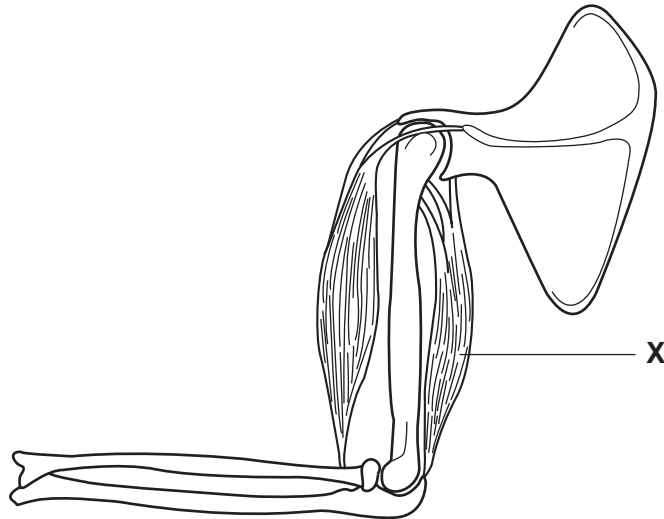

What happens when muscle X contracts?

- A The lower arm is extended.
 - B The lower arm is raised.
 - C The upper arm is raised.
 - D The whole arm rotates.
- 23 In what way is carbon monoxide in tobacco smoke harmful?
- A It causes emphysema.
 - B It causes lung cancer.
 - C It combines with haemoglobin.
 - D It kills the cells lining the trachea.

24 The diagram shows part of the nervous system, including a reflex arc. It has been cut

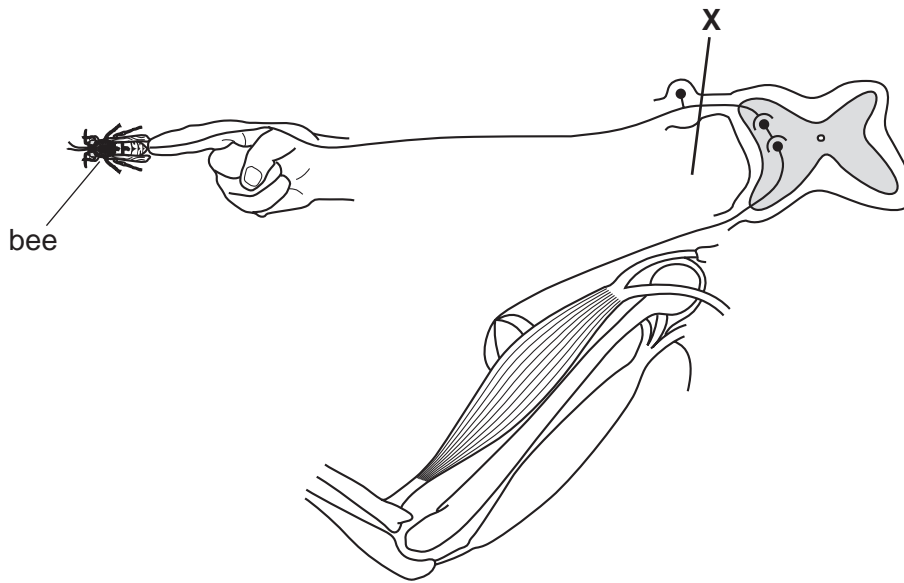

A bee stings a finger, as shown.

What are the effects of this sting?

	pain felt	arm moved
A	no	no
B	no	yes
C	yes	no
D	yes	yes

25 The urine of a person suffering from diabetes mellitus is likely to contain an abnormal amount of

- A** amino acids.
- B** fatty acids.
- C** glucose.
- D** urea.

26 In a nerve pathway, the following events take place.

1. activation of muscle
2. activation of receptor
3. passage of impulses along a motor neurone
4. passage of impulses along a sensory neurone

What is the correct order of these events?

	first	—————>			last
A	2	3	4	1	
B	2	4	3	1	
C	4	1	3	2	
D	4	2	1	3	

27 In a food chain, which trophic level has the most energy passing through it?

- A** carnivores
- B** decomposers
- C** herbivores
- D** producers

28 The diagram shows part of the carbon cycle.

Where in the cycle is there a food chain?

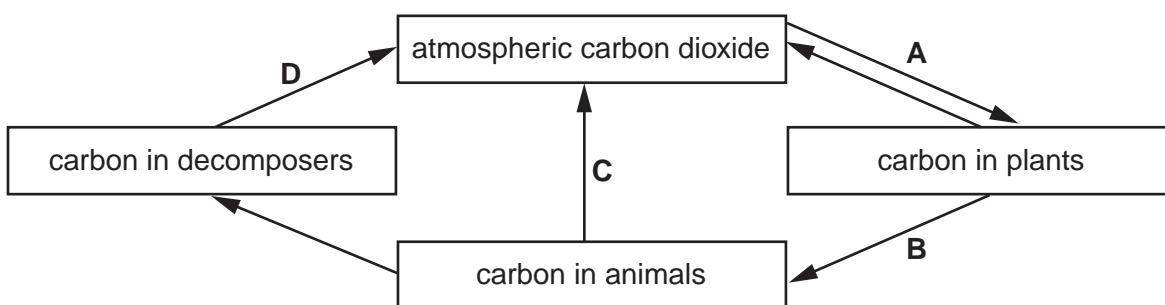

29 The diagram represents the flow of energy in an ecosystem during one year.

Which box represents the largest total mass of living organisms?

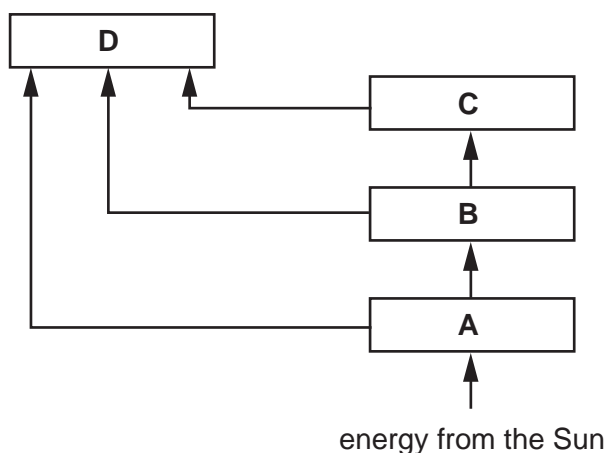

30 Which process does **not** result in the return of carbon dioxide to the atmosphere?

- A combustion of fossil fuels
- B decomposition of humus
- C photosynthesis by green plants
- D respiration by bacteria

31 Which method of control would **not** be effective against the spread of the malarial parasite?

- A drainage of swamps and marshes
- B isolation of infected people
- C sewage treatment and disposal under cover
- D spraying walls of houses with insecticide

32 During a growing season, one half of a field was treated with selective weedkiller, while the other half was left untreated. The table shows the numbers of four common weeds in each half of the field at the beginning and at the end of the season.

Which weed was best controlled by the weedkiller?

weed	untreated part of field		treated part of field	
	beginning of season	end of season	beginning of season	end of season
A	75	70	65	60
B	480	490	515	25
C	20	25	25	20
D	100	90	95	220

33 The diagram shows a potato plant reproducing asexually by tubers.

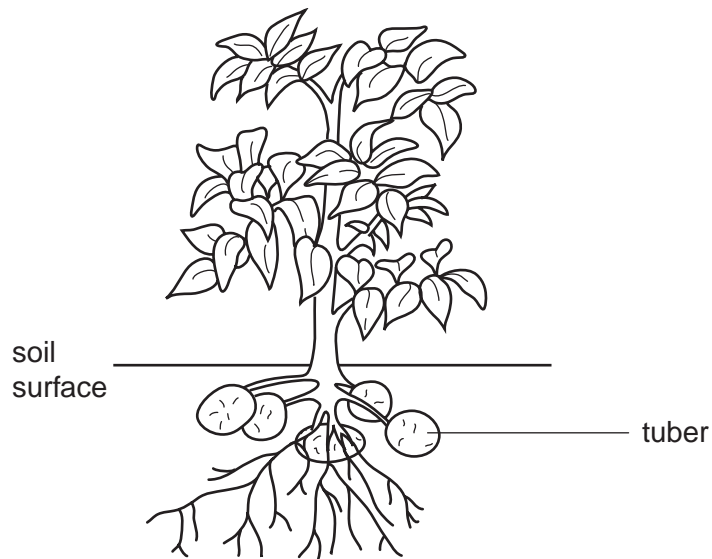

Four observations were made about the potato plant.

1. There is one parent plant.
2. The tubers are attached to the parent.
3. The tubers are genetically identical to the parent.
4. The tubers store food.

Which of these observations describe asexual reproduction?

- A 1 and 3
- B 1 and 4
- C 2 and 3
- D 2 and 4

34 When is ovulation most likely to occur?

- A about halfway between the start of one menstruation and the next
- B at the start of menstruation
- C 1-5 days before the start of menstruation
- D 5-10 days after the start of menstruation

35 The diagram shows the 28 days of the menstrual cycle.

When does the lining of the uterus break down?

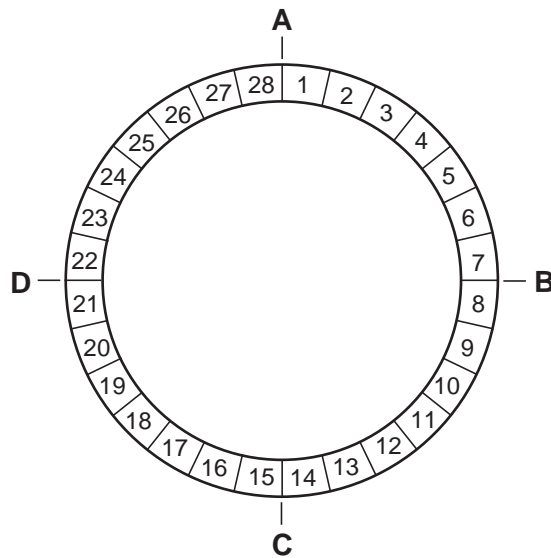

36 Four jars containing seeds were set up at room temperature, as shown.

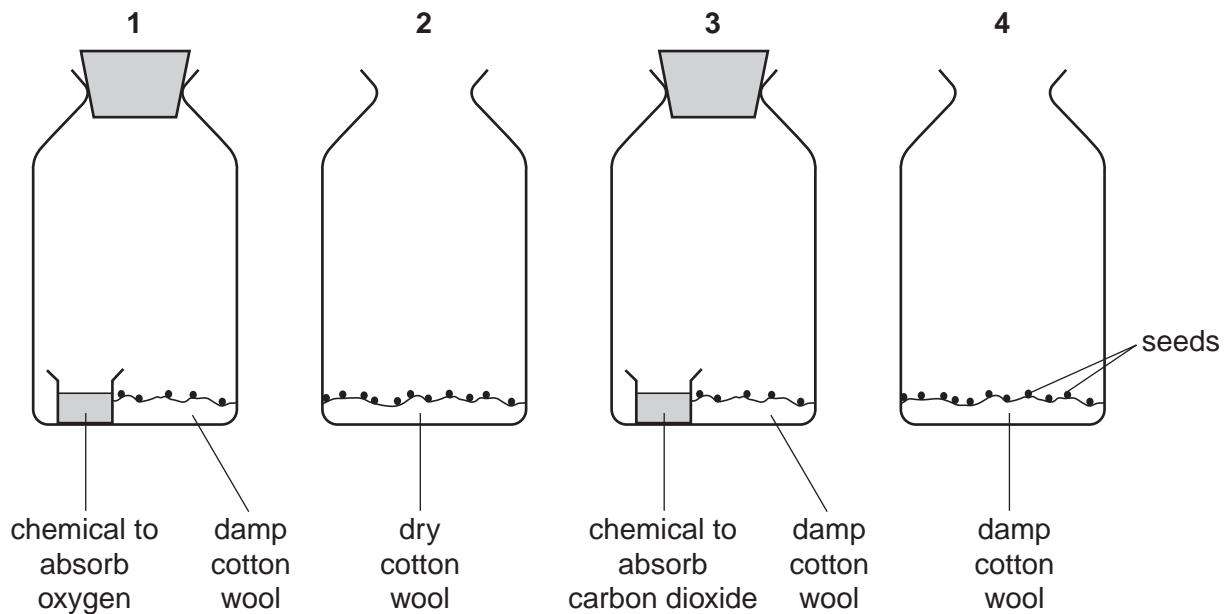

In which two jars is germination most likely to occur?

- A** 1 and 2 **B** 1 and 4 **C** 2 and 3 **D** 3 and 4

37 Which statement about sperm cells is correct?

- A** They contain either one X or one Y chromosome.
B They contain one X chromosome.
C They contain one Y chromosome.

- 38 The bar charts show the percentages of a human population with each type of blood group and the percentages of a cattle population with and without horns.

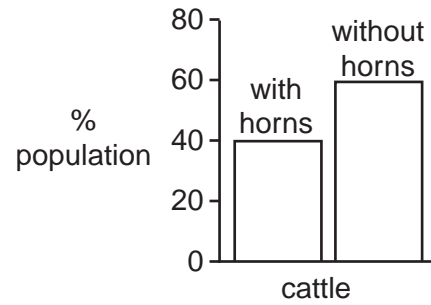
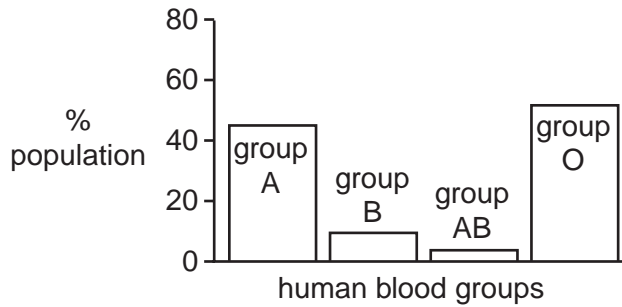

Which type of variation is shown in each population?

	human	cattle
A	continuous	continuous
B	continuous	discontinuous
C	discontinuous	continuous
D	discontinuous	discontinuous

- 39 A variety of snail has an inherited condition that affects the thickness of the shell.

$S^t S^t$ have thick shells.
 $S^t S^n$ have thin shells.
 $S^n S^n$ do **not** survive.

Two heterozygous snails are mated.

What is the probability that a surviving snail of the next generation is a heterozygote?

- A** 0.00
- B** 0.25
- C** 0.50
- D** 0.67

- 40 Polydactyly is a rare condition that causes the development of extra fingers. This is caused by a dominant allele. The diagram shows the inheritance of polydactyly in a family.

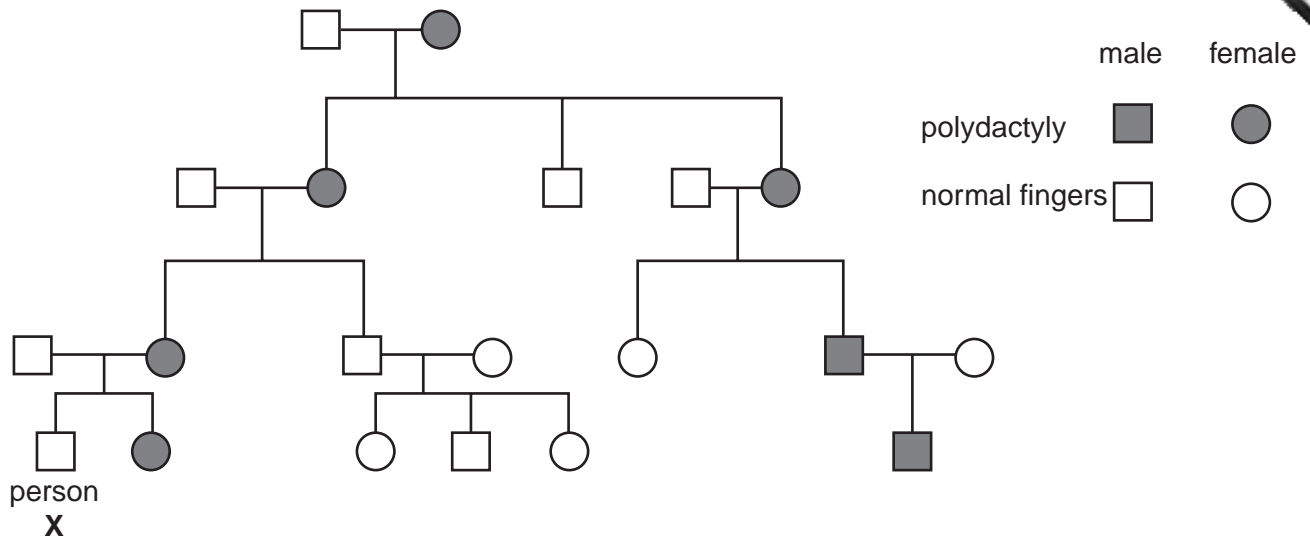

What is the probability that children of person X will inherit polydactyly from him?

- A 0.00
 B 0.25
 C 0.50
 D 1.00

